

650V N-Channel Enhancement Mode Power IGBT

MAIN CHARACTERISTICS

I_c @TC=100°C	75A
V_{CE}	650V
VCE(sat)-typ	1.6V

FEATURES

- ◆ Positive temperature coefficient
- ◆ Fast Switching
- ◆ Low VCE(sat)
- ◆ Reliable and Rugged

APPLICATIONS

- ◆ UPS
- ◆ Motor drives
- ◆ Boost
- ◆ Portable power station

MECHANICAL DATA

- ◆ Case: Molded plastic
- ◆ Mounting Position: Any
- ◆ Molded Plastic: UL Flammability Classification Rating 94V-0
- ◆ Lead free in compliance with EU RoHS 2011/65/EU directive
- ◆ Solder bath temperature 275°C maximum,10s per JESD 22-B106

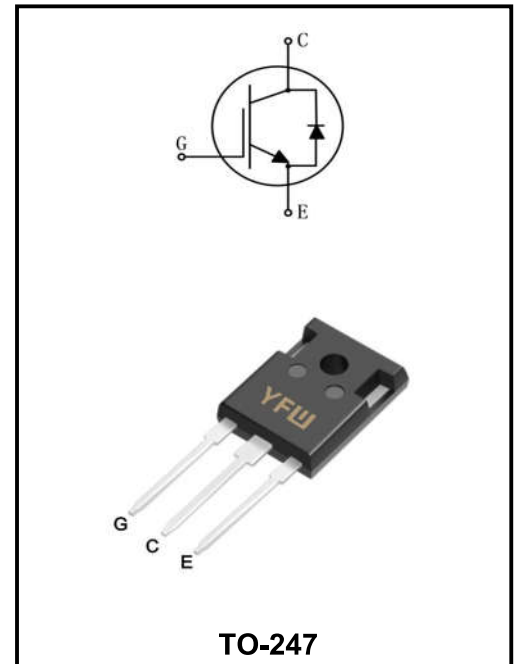

Maximum Ratings

Characteristics	Symbol	Value	Unit
Collector-emitter voltage	V_{CES}	650	V
Gate-emitter voltage	V_{GES}	±30	V
Continuous collector current (TC=25°C)	I_c	150	A
Continuous collector current (TC=100°C)		75	A
Pulsed collector current, tp limited by Tvjmax	I_{CM}	300	A
Diode continuous forward current (TC=25°C)	I_F	150	A
Diode continuous forward current (TC=100°C)		75	A
Diode maximum current, tp limited by Tvjmax	I_{FM}	300	A
Operating junction temperature range	T_{vj}	-55 to +175	°C
Storage temperature range	T_{stg}	-55 to +175	°C

Thermal characteristics

Characteristics	Symbol	Values		Unit
		Typ	Max.	
Thermal resistance, junction to case for IGBT	R_{th(j-c)}	-	0.38	K/ W
Thermal resistance, junction to case for Diode	R_{th(j-c)}	-	0.44	K/ W
Thermal resistance, junction to ambient	R_{th(j-a)}	-	40	K/ W

Note1:Pulse test: 300 μs pulse width, 2 % duty cycle

Electrical characteristics of IGBT at $T_{vj}=25^{\circ}\text{C}$ unless otherwise specified

Characteristics	Test Condition	Symbol	Min	Typ	Max	Unit	
Collector-emitter breakdown voltage	$V_{GE}=0V, I_c=250\mu A$	$B_{V_{CES}}$	650	-	-	V	
Collector-emitter leakage current	$V_{CE}=650V, V_{GE}=0V$	I_{CES}	-	-	10	μA	
Gate leakage current, forward	$V_{GE}=\pm 20V, V_{CE}=0V$	I_{GES}	-	-	± 200	nA	
Gate-emitter threshold voltage	$V_{GE}=V_{CE}, I_c=1mA$	$V_{GE(th)}$	4.3	5.3	6.3	V	
Collector-emitter saturation voltage	$V_{GE}=15V, I_c=75A$	$V_{CE(sat)}$	-	1.6	2	V	
	$V_{GE}=15V, I_c=75A, T_{vj}=125^{\circ}\text{C}$		-	1.88	-	V	
	$V_{GE}=15V, I_c=75A, T_{vj}=175^{\circ}\text{C}$		-	2.08	-	V	
Input capacitance	$V_{CE}=25V$ $V_{GE}=0V$ $f=1MHz$	C_{ies}	-	5660	-	pF	
Output capacitance		C_{oes}	-	260	-	pF	
Reverse transfer capacitance		C_{res}	-	154	-	pF	
Total gate charge	$V_{CC}=520V, V_{GE}=15V, I_c=75A$	Q_g	-	320	-	nC	
Gate- Emitter Charge		Q_{ge}	-	50	-	nC	
Gate- Collector Charge		Q_{gc}	-	155	-	nC	
Short circuit collector current Max.1000 short circuits, times between short circuits: $\geq 1.0s$	$V_{GE}=15V, V_{CC}\leq 400V, T_{j}\leq 175^{\circ}\text{C}$	$t(SC)$	-	9	-	μs	
Turn-on delay time	$V_{CC}=400V$ $V_{GE}=15V$ $I_c=75A$ $R_G=5\Omega$ Inductive load	$t_d(on)$	-	32	-	ns	
Rise time		t_r	-	133	-	ns	
Turn-off delay time		$t_d(off)$	-	187	-	ns	
Fall time		t_f	-	107	-	ns	
Turn-on energy		E_{on}	-	3.04	-	mJ	
Turn-off energy		E_{off}	-	2.33	-	mJ	
Total switching energy		E_{ts}	-	5.37	-	mJ	
Turn-on delay time		$V_{CC}=400V$ $V_{GE}=15V$ $I_c=75A$ $R_G=5\Omega$ Inductive load $T_{vj}=175^{\circ}\text{C}$	$t_d(on)$	-	30	-	ns
Rise time			t_r	-	138	-	ns
Turn-off delay time			$t_d(off)$	-	202	-	ns
Fall time	t_f		-	126	-	ns	
Turn-on energy	E_{on}		-	4.67	-	mJ	
Turn-off energy	E_{off}		-	4.2	-	mJ	
Total switching energy	E_{ts}		-	8.87	-	mJ	
Diode forward voltage	$I_F=75A$		V_F	-	1.68	2.08	V
	$I_F=75A, T_{vj}=125^{\circ}\text{C}$	-		1.53	-	V	
	$I_F=75A, T_{vj}=175^{\circ}\text{C}$	-		1.43	-	V	
Diode reverse recovery time	$V_R=400V$ $I_F=75A$ $di_F/dt=-200A/\mu s$	t_{rr}	-	136	-	ns	
Diode peak reverse recovery current	$V_R=400V$ $I_F=75A$ $di_F/dt=-200A/\mu s, T_{vj}=175^{\circ}\text{C}$	I_{rrm}	-	6.3	-	A	
Diode reverse recovery charge		Q_{rr}	-	430	-	nC	
Diode reverse recovery time		t_{rr}	-	183	-	ns	
Diode peak reverse recovery current	$V_R=400V$ $I_F=75A$ $di_F/dt=-200A/\mu s, T_{vj}=175^{\circ}\text{C}$	I_{rrm}	-	8.5	-	A	
Diode reverse recovery charge		Q_{rr}	-	670	-	nC	

RATINGS AND CHARACTERISTIC CURVES

Figure 1: Power Dissipation

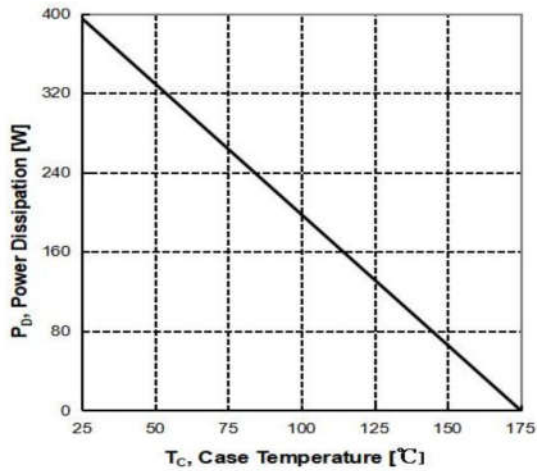

Figure 2: Collector Current vs. Case Temperature

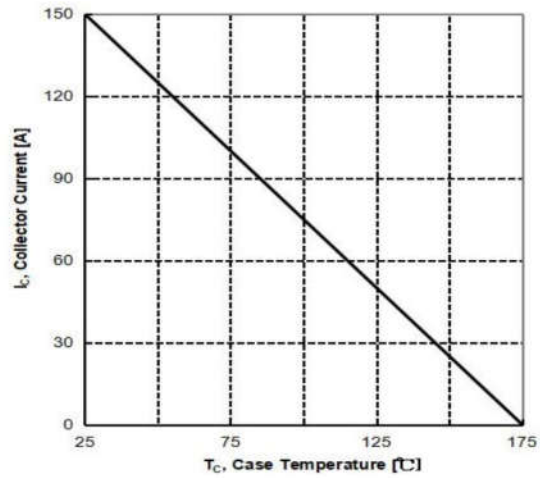

Figure 3: Safe Operation Area

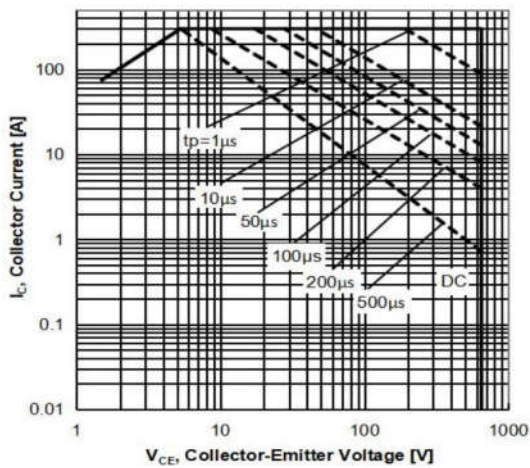

Figure 4: Typical Transfer Characteristics

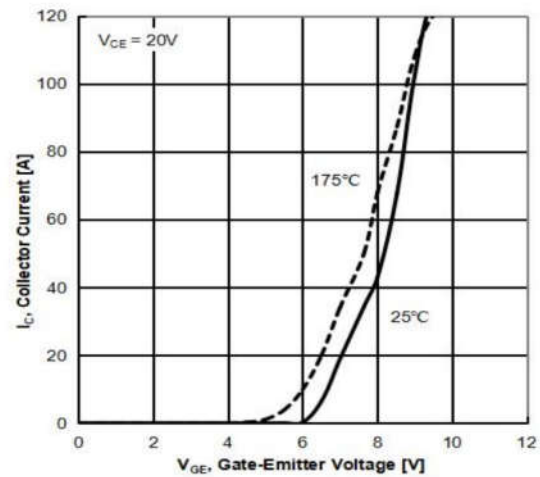

Figure 5: Typical Output Characteristics

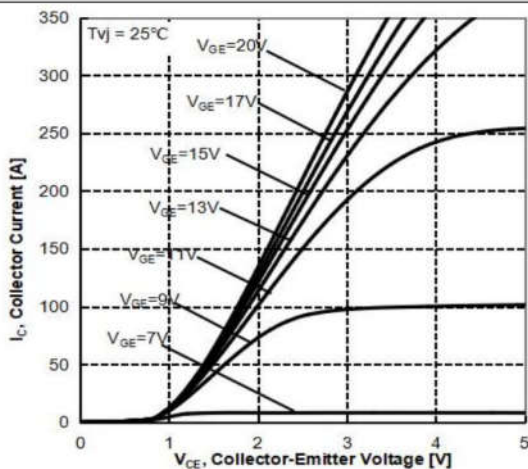

Figure 6: Typical Output Characteristics

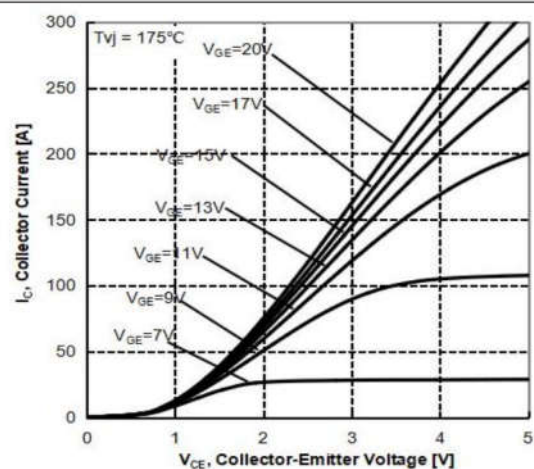

Figure 7: Typical Collector-Emitter Saturation Voltage vs. Junction Temperature

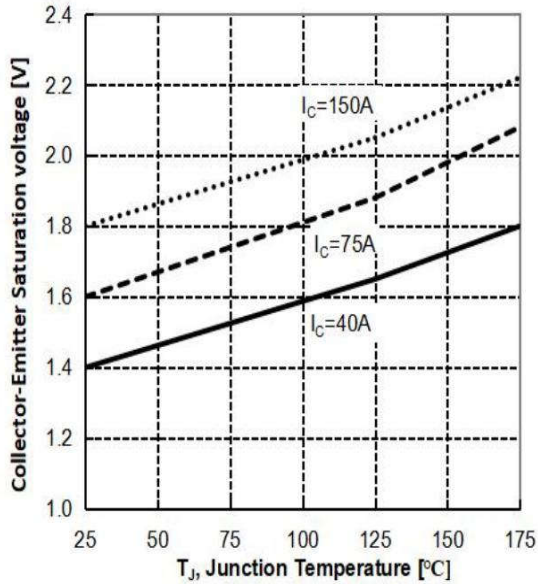

Figure 8: Typical Gate-Emitter Threshold Voltage vs. Junction Temperature

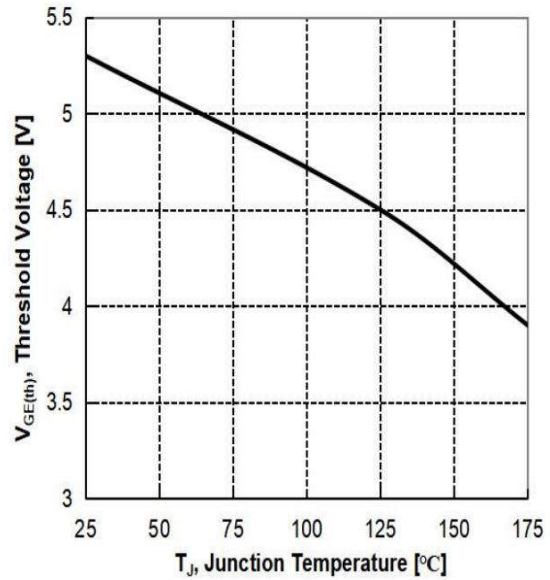

Figure 9: Typical Switching Times vs. Gate Resistor ($T_J=25^\circ\text{C}$, $V_{CE}=400\text{V}$, $V_{GE}=15/0\text{V}$, $I_C=75\text{A}$)

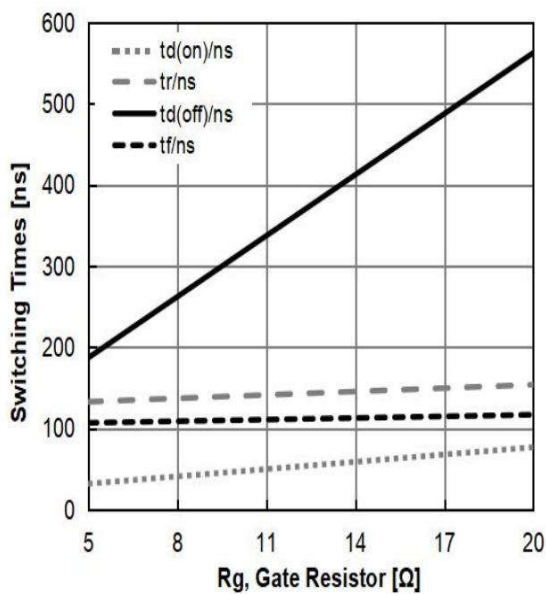

Figure 10: Typical Switching Energy vs. Gate Resistor ($T_J=25^\circ\text{C}$, $V_{CE}=400\text{V}$, $V_{GE}=15/0\text{V}$, $I_C=75\text{A}$)

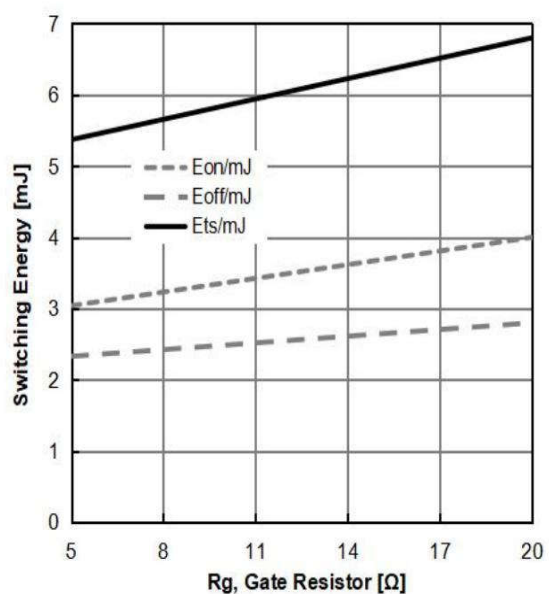

Figure 11: Typical Switching Times vs. Junction Temperature ($V_{CE}=400V$, $V_{GE}=15/0V$, $I_C=75A$)

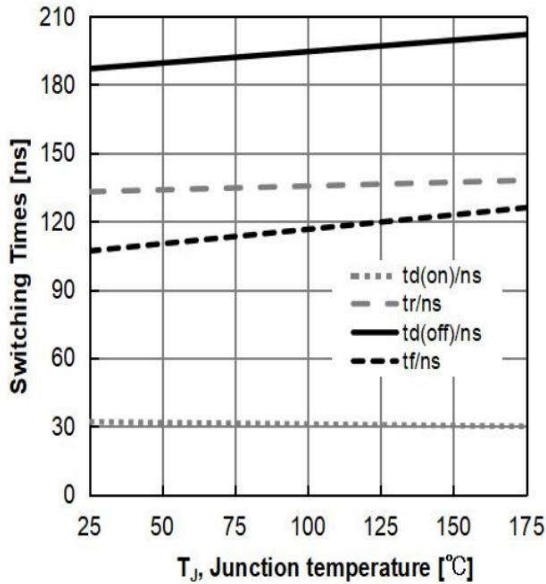

Figure 12: Typical Switching Energy vs. Junction Temperature ($V_{CE}=400V$, $V_{GE}=15/0V$, $I_C=75A$)

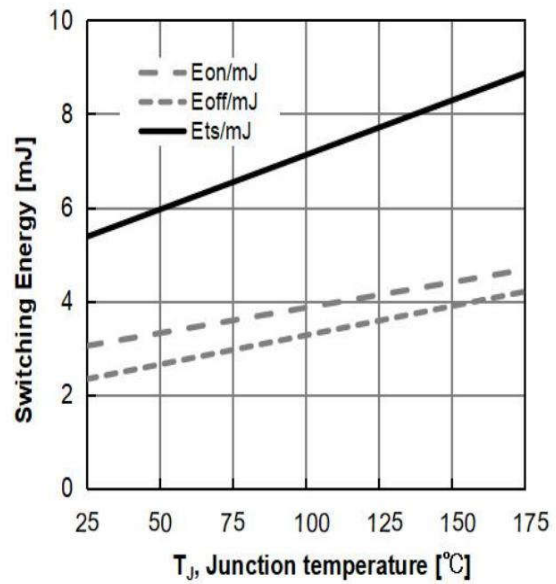

Figure 13: Typical Switching Times vs Collector Current ($T_J=25^\circ C$, $V_{CE}=400V$, $V_{GE}=15/0V$)

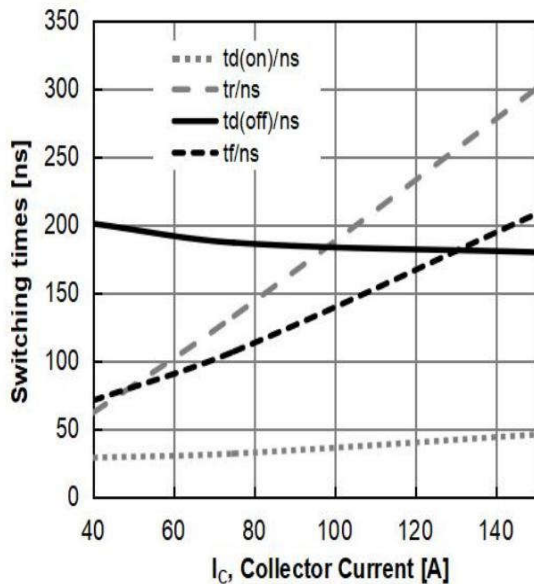

Figure 14: Typical Switching Energy vs Collector Current ($T_J=25^\circ C$, $V_{CE}=400V$, $V_{GE}=15/0V$)

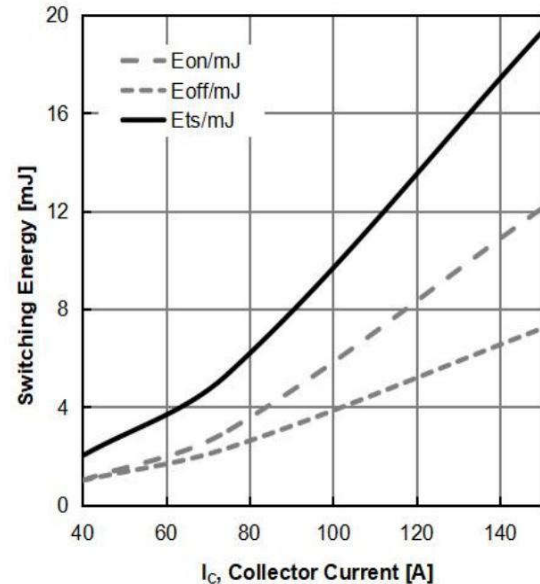

Figure 15: Typical Switching Times vs. VCE ($T_J=25^{\circ}\text{C}, V_{GE}=15/0\text{V}, I_C=75\text{A}$)

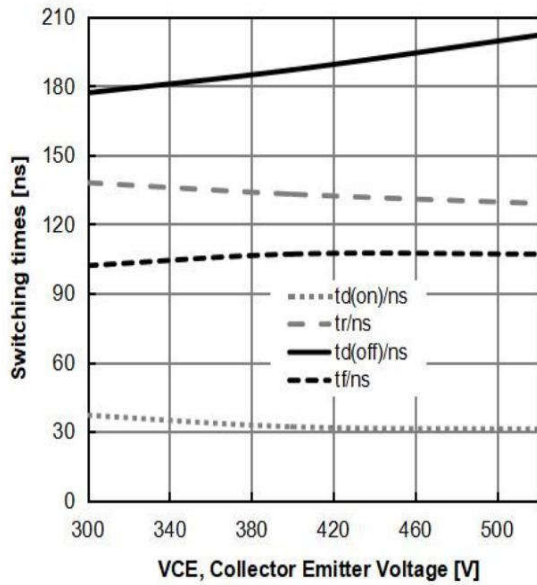

Figure 16: Typical Switching Energy vs. VCE ($T_J=25^{\circ}\text{C}, V_{GE}=15/0\text{V}, I_C=75\text{A}$)

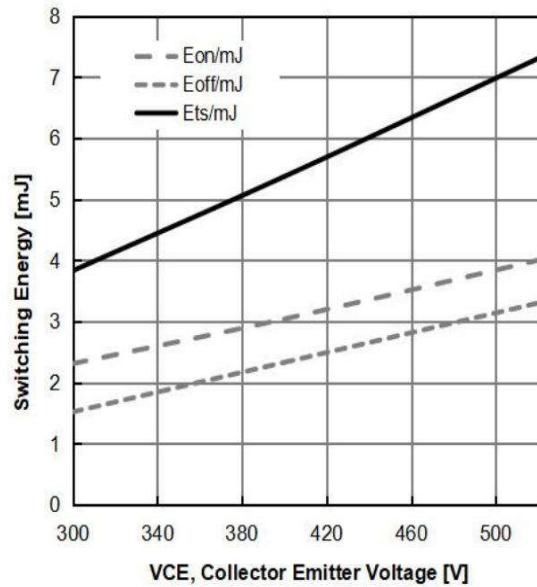

Figure 17: Typical Gate Charge

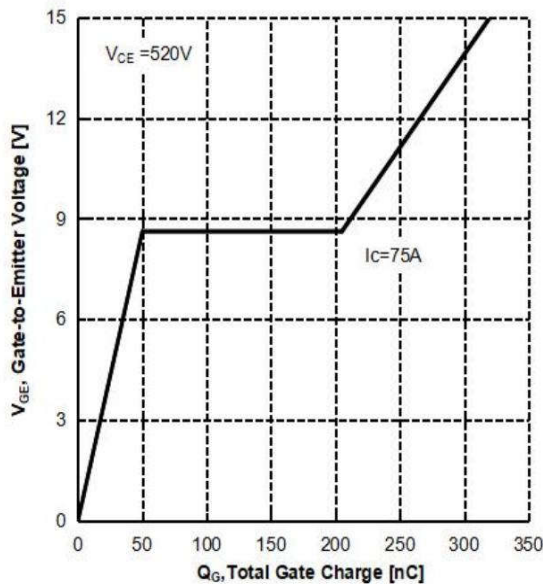

Figure 18: Typical Capacitance vs. Collector- Emitter Voltage

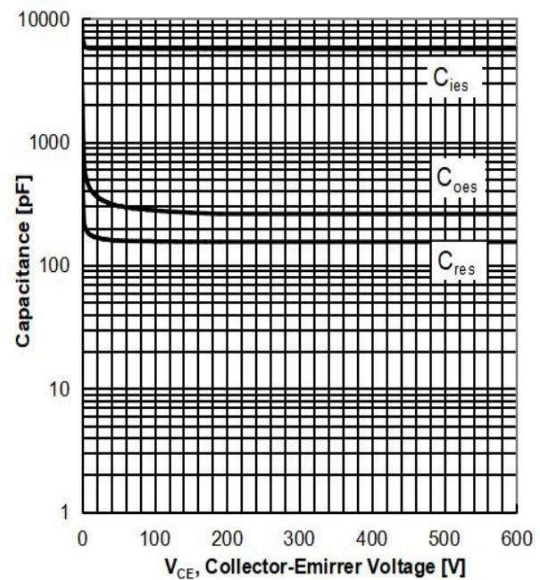

Figure 19: IGBT Transient Thermal Impedance vs. Pulse Width

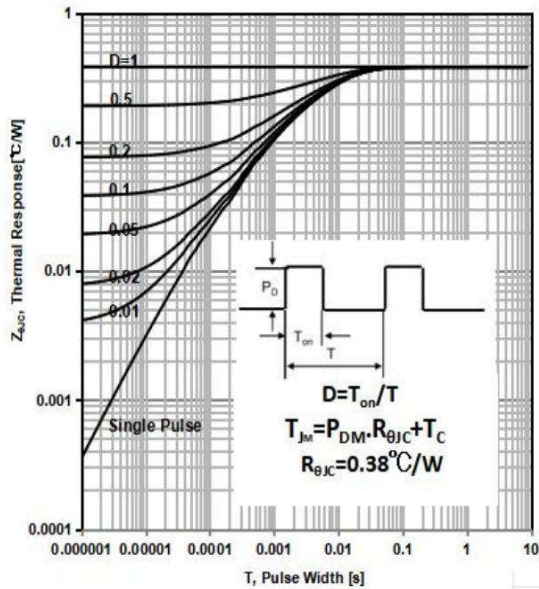

Figure 20: Diode Transient Thermal Impedance vs. Pulse Width

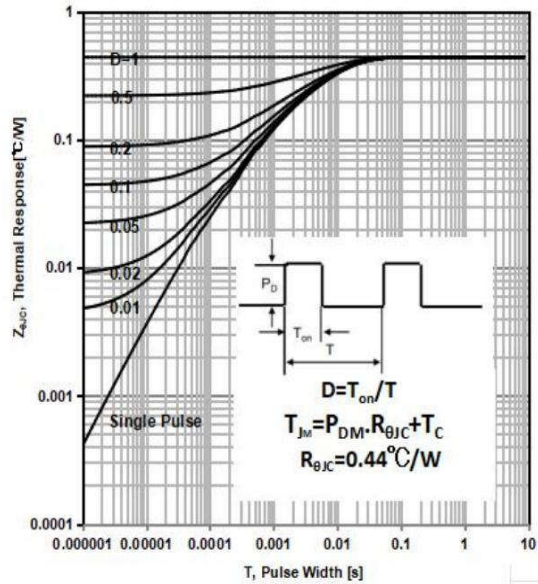
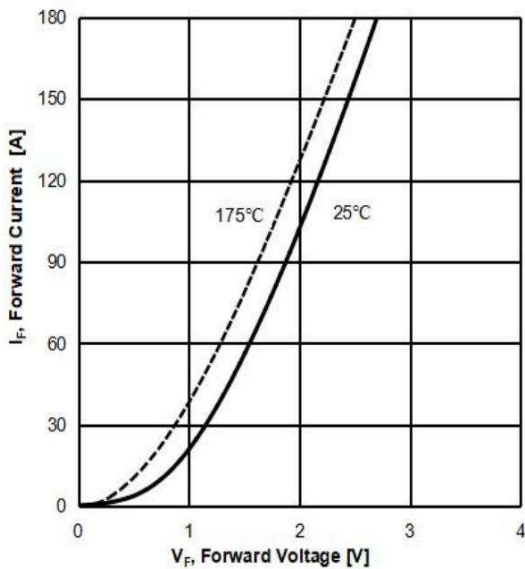
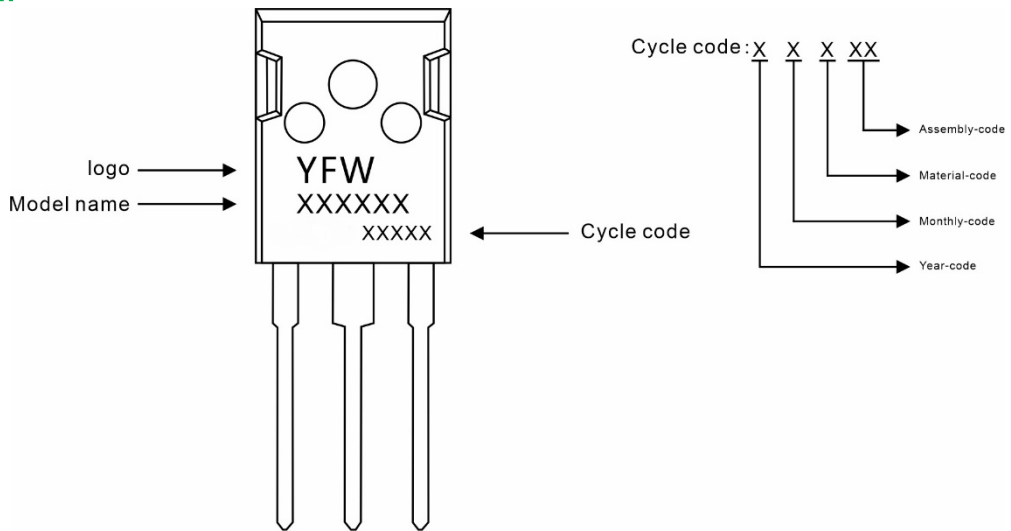

Figure 21: Typical Diode Forward Current vs. Forward Voltage



Marking Diagram



Ordering information

Model name	Package	Unit Weight	Base Quantity	Packing Quantity
YFWG75T65LAP	TO-247	0.209oz(5.93g)	30pcs/tube	600PCS/Box 2400PCS/Carton

Package Dimensions

TO-247

Symbol	Dimensions in mm		Dimensions in Inch	
	Min.	Max.	Min.	Max.
A	4.90	5.10	0.193	0.201
A1	1.90	2.10	0.075	0.083
A2	2.29	2.54	0.090	0.100
b	1.00	1.40	0.039	0.055
b1	2.00	2.20	0.079	0.087
b2	3.00	3.20	0.118	0.126
c	0.50	0.70	0.020	0.028
D	15.75	16.05	0.620	0.632
E	20.20	20.80	0.795	0.819
e	5.45 (BSC)		0.215 (BSC)	
e1	10.90 (BSC)		0.429 (BSC)	
F	6.05	6.25	0.238	0.246
F1	5.80	6.00	0.228	0.236
L	20.10	20.40	0.791	0.803
L1	4.05	4.35	0.159	0.171
Φ	3.50	3.70	0.138	0.146

Disclaimer

The information presented in this document is for reference only. Guangdong Youfeng Microelectronics Co.,Ltd. reserves the right to make changes without notice for the specification of the products displayed herein to improve reliability, function or design or otherwise. The product listed herein is designed to be used with ordinary electronic equipment or devices, and not designed to be used with equipment or devices which require high level of reliability and the malfunction of which would directly endanger human life (such as medical instruments, transportation equipment, aerospace machinery, nuclear-reactor controllers, fuel controllers and other safety devices), YFW or anyone on its behalf, assumes no responsibility or liability for any damages resulting from such improper use of sale. This publication supersedes & replaces all information previously supplied. For additional information, please visit our website <https://www.yfwdiode.com>, or consult YFW sales office for further assistance.