

15A Super Fast Recovery Rectifier Bridge

Reverse Voltage - 300 to 600 V
Forward Current –15A

FEATURES

- ◆Surge overload rating-220 amperes peak
- ◆Polarity: As marked on body
- ◆Ideal for printed circuit board
- ◆Plastic material has U/L The flammability classification 94V-0
- ◆Reliable low cost construction utilizing molded plastic technique

MECHANICAL DATA

- ◆Case: GBU
- ◆Terminals: Solderable per MIL-STD-202, Method208
- ◆Approx. Weight: 3.9g /0.138oz

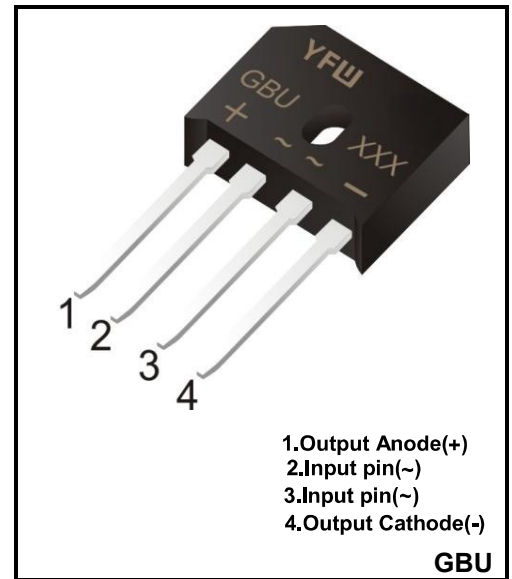

Maximum Ratings and Electrical characteristics

Ratings at 25 °C ambient temperature unless otherwise specified.

Single phase half-wave 60 Hz, resistive or inductive load, for capacitive load current derate by 20 %.

Parameter	Symbols	GBU1503SF	GBU1506SF	Units
Maximum Repetitive Peak Reverse Voltage	V_{RRM}	300	600	V
Maximum RMS voltage	V_{RMS}	200	420	V
Maximum DC Blocking Voltage	V_{DC}	300	600	V
Maximum Average Forward $T_C=100^{\circ}C$ Rectified Current at	$I_{(AV)}$	15		A
Peak Forward Surge Current 8.3 ms Single Half Sine-Wave Superimposed on Rated Load (JEDEC method)	I_{FSM}	250		A
Forward Voltage per element @ $I_F=15A$ DC	V_F	1.20	1.50	V
Maximum DC Reverse Current at Rated DC Blocking Voltage @ $T_a=25^{\circ}C$ @ $T_a=125^{\circ}C$	I_R	10 500		μA
I^2t Rating for Fusing($3ms \leq t \leq 8.3ms$)	I^2t	200		A^2S
Typical Junction Capacitance (Note1)	C_j	86		pF
Maximum Reverse Recovery Time (Note2)	T_{rr}	38	45	nS
Typical Thermal Resistance (Note2)	$R_{\theta JC}$	2.0		$^{\circ}C/W$
Operating and Storage Temperature Range	T_j, T_{stg}	-55 ~ +175		$^{\circ}C$

(1) Measured at 1 MHz and applied reverse voltage of 4 V D.C

(2) Device mounted on 150mm*150mm*16mm cu plate heatsink

Ratings and Characteristic Curves

FIG. 1- DERATING CURVE OUTPUT RECTIFIED CURRENT

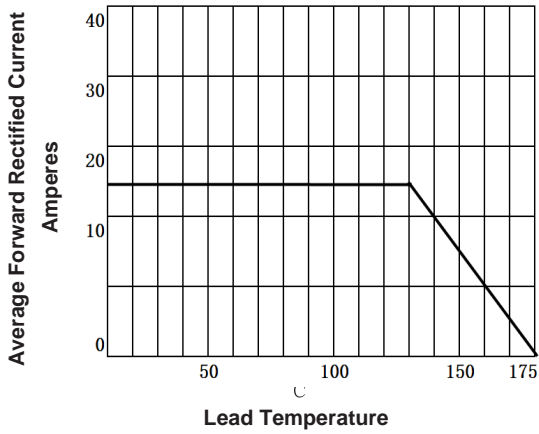

FIG. 2-MAXIMUM NON-REPETITIVE PEAK FORWARD SURGE CURRENT PER LEG

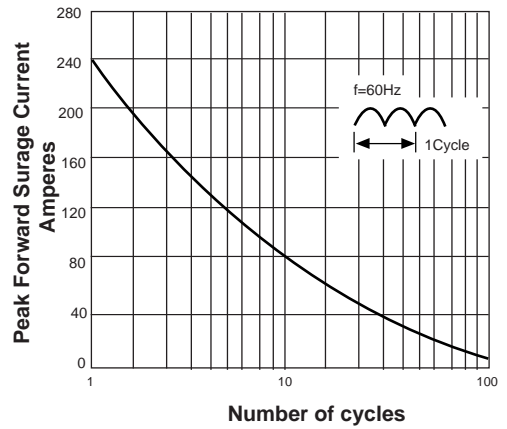

FIG. 3-TYPICAL FORWARD VOLTAGE CHARACTERISTICS

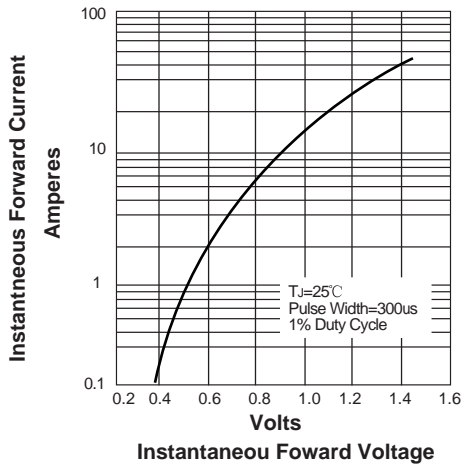
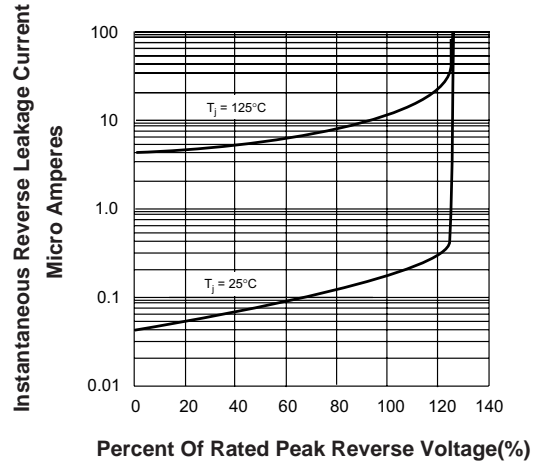
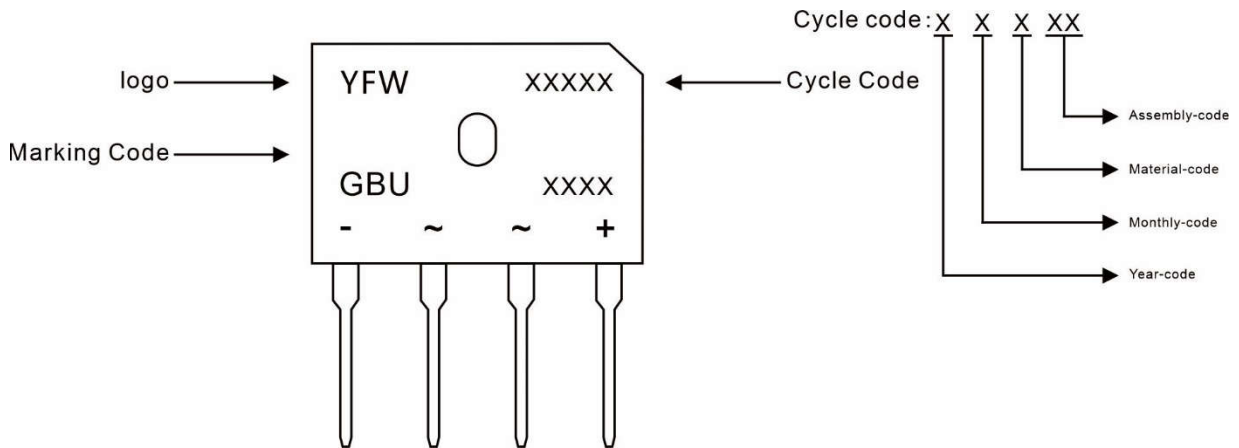

FIG. 4-TYPICAL REVERSE LEAKAGE CHARACTERISTICS



Marking Diagram



Ordering information

Package	Packing Description	Packing Quantity
GBU	bulk	500PCS/Box 5000PCS/Carton

Package Dimensions

GBU

Dim	Millimeter(mm)		Dimensions inInch	
	Min.	Max.	Min.	Max.
A	21.70	22.30	0.86	0.88
B	18.20	18.80	0.72	0.74
C	1.60	2.00	0.06	0.08
D	1.60	2.00	0.06	0.08
E	1.80	2.20	0.07	0.09
F	2.00	2.40	0.08	0.09
G	0.90	1.30	0.04	0.05
H	3.00	/	0.12	/
I	4.88	5.28	0.19	0.21
J	3.20	3.60	0.13	0.14
K	1.70	2.10	0.07	0.08
L	17.50	18.50	0.69	0.73
M	0.40	0.60	0.02	0.02

Disclaimer

The information presented in this document is for reference only. Guangdong Youfeng Microelectronics Co.,Ltd. reserves the right to make changes without notice for the specification of the products displayed herein to improve reliability, function or design or otherwise. The product listed herein is designed to be used with ordinary electronic equipment or devices, and not designed to be used with equipment or devices which require high level of reliability and the malfunction of which would directly endanger human life (such as medical instruments, transportation equipment, aerospace machinery, nuclear-reactor controllers, fuel controllers and other safety devices), YFW or anyone on its behalf, assumes no responsibility or liability for any damages resulting from such improper use of sale. This publication supersedes & replaces all information previously supplied. For additional information, please visit our website <https://www.yfwdiode.com>, or consult YFW sales office for further assistance.