

## 2.0A Super Fast Recovery Rectifier Bridge

Reverse Voltage - 300 to 600 V  
Forward Current – 2.0A

### FEATURES

- ◆ High current capability
- ◆ Low forward voltage drop
- ◆ Glass Passivated Chip Junction
- ◆ Low power loss, high efficiency
- ◆ Lead free in comply with EU RoHS 2011/65/EU directives

### MECHANICAL DATA

- ◆ Case: D3K
- ◆ Terminals: Solderable per MIL-STD-202E, Method 208C
- ◆ Case: UL-94 Class V-0 recognized Flame Retardant Epoxy

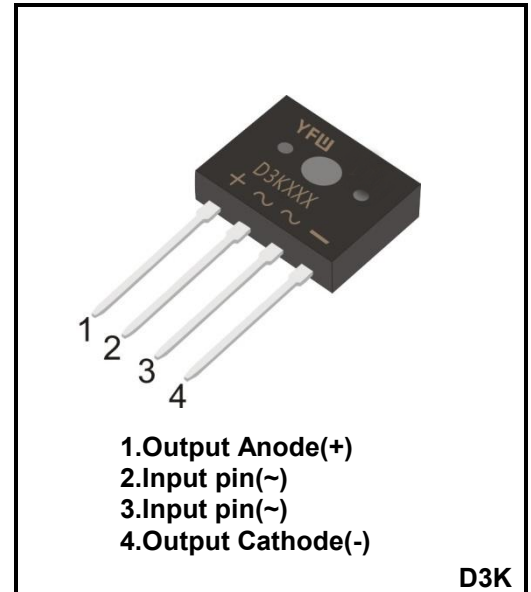

### Maximum Ratings and Electrical characteristics

Ratings at 25 °C ambient temperature unless otherwise specified.

Parameter	Symbols	D3K203SF	D3K206SF	Units
Maximum Repetitive Peak Reverse Voltage	$V_{RRM}$	300	600	V
Maximum RMS voltage	$V_{RMS}$	200	420	V
Maximum DC Blocking Voltage	$V_{DC}$	300	600	V
Average Rectified Output Current	$I_{(AV)}$	2.0		A
Peak Forward Surge Current 8.3 ms Single Half Sine-Wave Superimposed on Rated Load (JEDEC method)	$I_{FSM}$	60		A
Forward Voltage per element @ $I_F=2A$ DC	$V_F$	0.95	1.45	V
Maximum Reverse Recovery Time	$T_{rr}$	35		nS
Maximum DC Reverse Current at Rated DC Blocking Voltage	@ $T_a=25^{\circ}C$	5		$\mu A$
	@ $T_a=125^{\circ}C$	500		
$I^2t$ Rating for Fusing( $3ms \leq t \leq 8.3ms$ )	$I^2t$	17.5		$A^2S$
Typical Junction Capacitance	$C_j$	25		pF
Operating and Storage Temperature Range	$T_j, T_{stg}$	-55 ~ +175		$^{\circ}C$

(1) Measured at 1 MHz and applied reverse voltage of 4 V D.C

(2) Device mounted on 50mm\*50mm\*1.6mm cu plate heatsink

**Ratings and Characteristic Curves**

FIG.1-DERATING CURVE OUTPUT RECTIFIED CURRENT

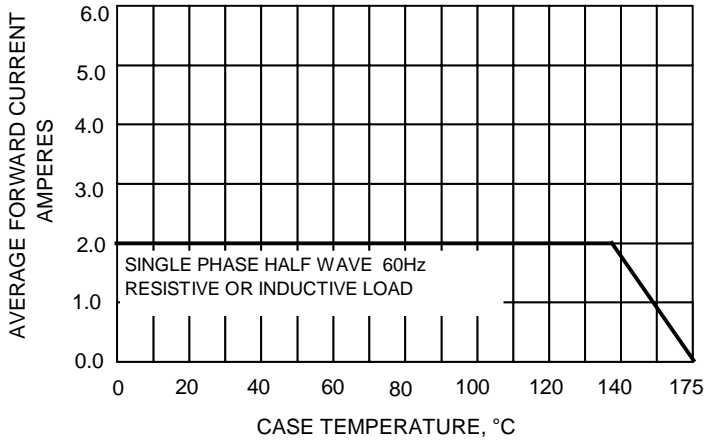

FIG.2-MAXIMUM NON-REPETITIVE SURGE CURRENT

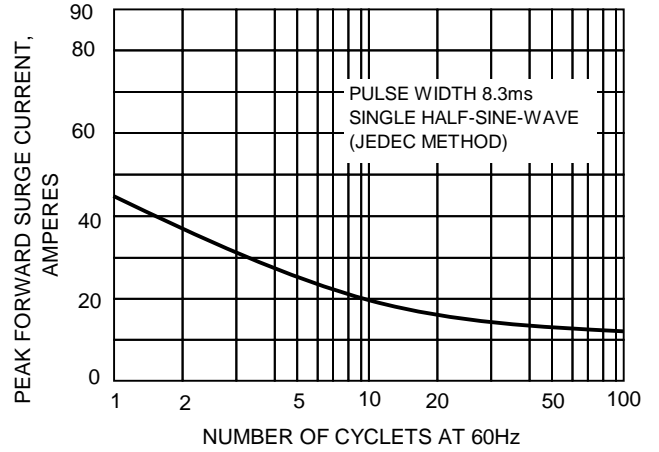

FIG.3-TYPICAL FORWARD CHARACTERISTICS

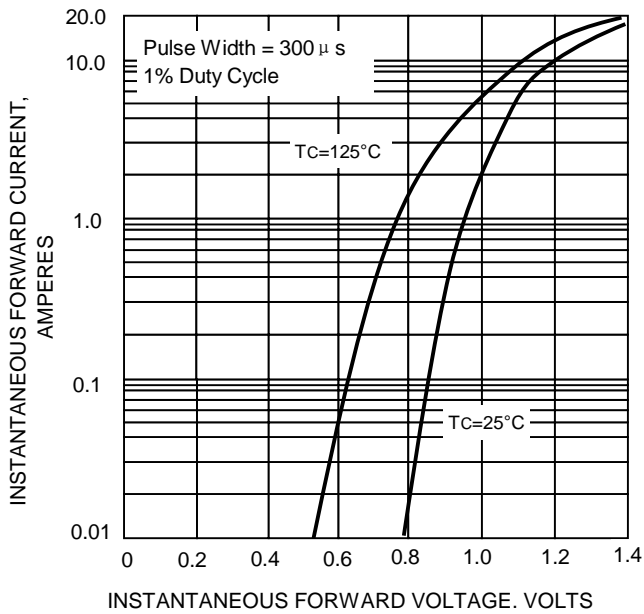
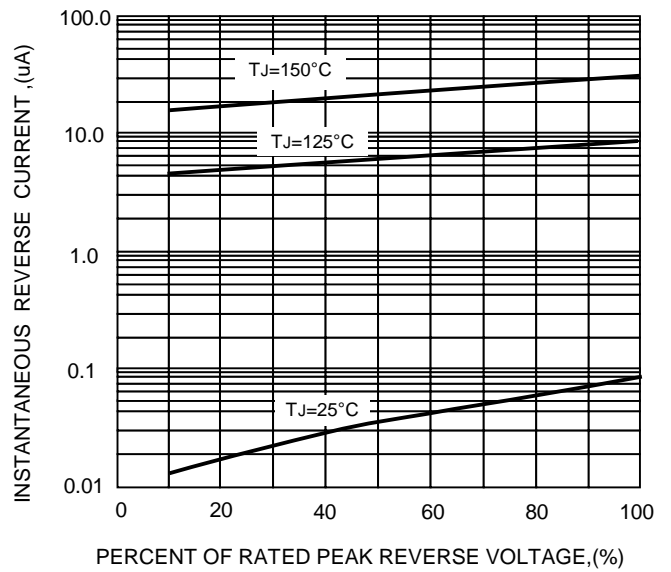
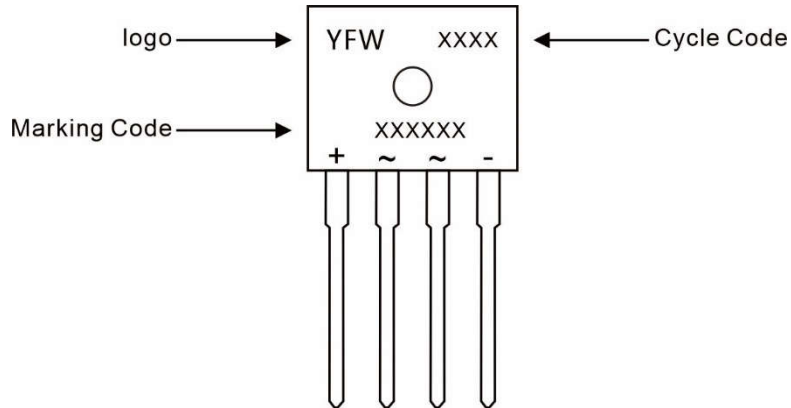

FIG.5-TYPICAL REVERSE CHARACTERISTICS



**Marking Diagram**



**Ordering information**

Package	Packing Description	Packing Quantity
D3K	bulk	500PCS/Box 5000PCS/Carton

**Package Dimensions**

**D3K**

Dim.	Millimeter(mm)		Dimensions inInch	
	Min.	Max.	Min.	Max.
A	13.5	14.5	0.53	0.57
B	10.0	11.0	0.39	0.43
C	1.8	2.4	0.07	0.09
D	12.8	14.8	0.50	0.58
E	3.76	3.86	0.15	0.15
F	0.65	0.85	0.03	0.03
G	1.2	1.4	0.05	0.06
H	5.0	5.5	0.20	0.22
I	3.05	3.45	0.12	0.14
J	3.1	3.6	0.12	0.14

## Disclaimer

The information presented in this document is for reference only. Guangdong Youfeng Microelectronics Co.,Ltd. reserves the right to make changes without notice for the specification of the products displayed herein to improve reliability, function or design or otherwise. The product listed herein is designed to be used with ordinary electronic equipment or devices, and not designed to be used with equipment or devices which require high level of reliability and the malfunction of which would directly endanger human life (such as medical instruments, transportation equipment, aerospace machinery, nuclear-reactor controllers, fuel controllers and other safety devices), YFW or anyone on its behalf, assumes no responsibility or liability for any damages resulting from such improper use of sale. This publication supersedes & replaces all information previously supplied. For additional information, please visit our website <https://www.yfwdiode.com>, or consult YFW sales office for further assistance.